

Using TURBOdesign1 Extensively at Voith Turbo for the Design of Hydrodynamic Torque Converters

By Dr. Andreas Basteck, General Manager Engineering,
Dr. Reinhard Kernchen, Head of Hydrodynamic Basis & Steffen
Kämmerer - Hydrodynamic Basis, Voith Turbo, Germany

Introduction

Voith Turbo is the leading manufacturer of hydrodynamic variable-speed couplings, variable-speed transmission couplings and torque converters. They are used in power generation, in the oil and gas industries as well as in the chemical and raw material industries to control pumps, compressors, and blowers, right up to starting systems of gas turbines. In short, wherever maximum operating safety and precise, high control dynamics at lowest operating and maintenance effort are required.

The application of hydro dynamically adjustable drives allows energy and cost savings, higher flexibility, longer service life of machinery and motor, less maintenance effort and use under adverse conditions with compact and robust designs. The output range reaches from 100 kW to 50,000 kW and speeds of up to 20,000 rpm.

What are torque converters?

The heart of Voith's hydrodynamic torque converter is its hydraulic circuit; consisting of a pump, turbine and a guide wheel with adjustable guide vanes. The mechanical energy of the motor is converted into hydraulic energy through the pump wheel. In the turbine wheel the same hydraulic energy is converted back into mechanical energy and transmitted to the output shaft.

With the arrangement of three bladed wheels (pump, turbine, guide vane) it is possible to obtain a torque conversion within the operation range. The adjustable vanes of the guide wheel regulate the mass flow in the circuit. At closed guide vanes (small mass flow) the power transmission is at its minimum. With the guide vanes completely open (large mass flow) the power transmission is at its maximum.

“The introduction of TURBOdesign1 also allowed Voith to minimize the number of CFD simulations required to optimize the hydrodynamic design of torque converters.”

VOITH

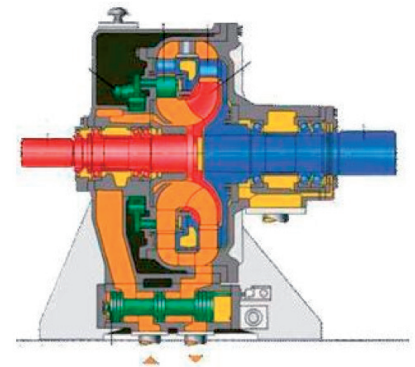

Fig.1. Torque converter

“The extensive use of TURBOdesign1 has enabled Voith Turbo to improve the aerodynamic design of their torque converters and to speed up the overall design process”



Fig.2. Design of stator

Design issues for variable speed torque converters

The design of torque converters and particularly of variable speed turbo couplings offers designers some unique and challenging problems, especially from a hydrodynamic point of view. The closed-loop circuit inside which the fluid evolves is composed of two or more components which must operate and interact efficiently. The variable design conditions, under which the torque converter has to operate, further complicate its hydrodynamic optimisation. Several design loops are usually necessary to optimise and “synchronise” the different components.

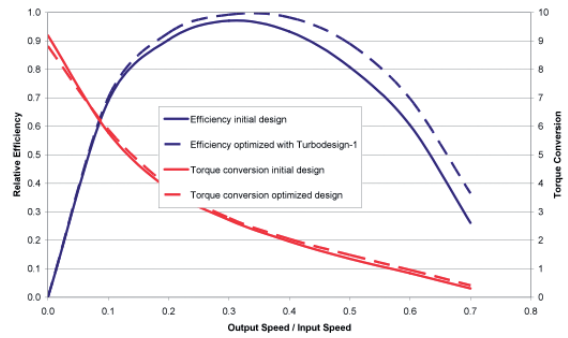

Fig. 3. Comparison of measured performance of inverse designed and conventional torque converter at 50% power output.

TURBODesign1 is now used extensively at Voith Turbo

With this in mind, the Voith Turbo design team decided to introduce TURBODesign1 into their design process in order to maximise the hydrodynamic performance of their torque converters and to speed up their design process.

Excellent results have been achieved in little time, as confirmed by the experimental campaign conducted on one of the original designs and on the new designs achieved using TURBODesign1 in combination with CFD.

Large efficiency improvements up to 10 points have been obtained by the optimisation of the hydrodynamic guide vane design over a wide range of speed ratios as shown in the data above.

Conclusion

By applying TURBODesign1 to torque converters it has been possible to achieve the best matching between components, control secondary flows and suppress flow separation.

The introduction of TURBODesign1 into Voith Turbo’s design process, enabled us to achieve significant improvements in the hydrodynamic performance of our blade designs, within very short time. The use of TURBODesign1 also enabled us to handle conflicting requirements in a straight-forward way.

“Voith Turbo manufactures drive systems that efficiently drive and move machinery on land or at sea, safely, reliably and comfortably propelling vehicles, saving energy and reducing emissions.”

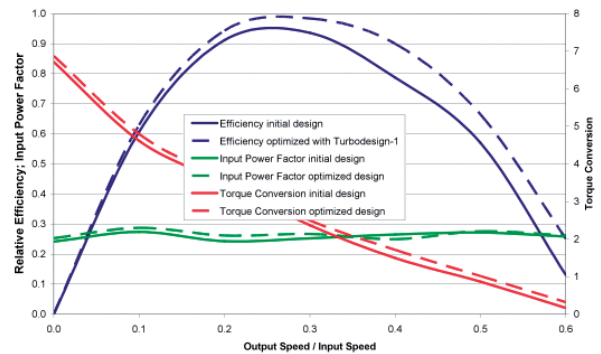

Fig. 4. Comparison of measured performance of inverse designed and conventional torque converter at 85% power output.